

WOOD N^o BEYOND

WE STAND BEHIND WHAT YOU STAND ON



Zhejiang Xinhaiye Bamboo Technology Co.,Ltd

Specification : 1850*137*18/20mm

Content

1. Introduction
2. Package
3. Installation
4. Maintenance
5. Warranty

Technology



WOOD N^o BEYOND

WE STAND BEHIND WHAT YOU STAND ON

1.Introduction

DassoCTECH is solid and high-density decking board, made from compressed bamboo fibres with a special, patented heat treatment process, making it one of the strongest, hardest and most durable materials on the market to create the perfect space for outdoor entertainment and relaxation. A unique feature of dassoCTECH is the head tongue and groove: this can only be done with very stable materials and enables connection of an unlimited number of boards in the length. The special symmetrical shape of the sides offers the possibility to choose between either the grooved or the flat surface and allows for quick installation with fasteners. Like any untreated tropical hardwood species, when exposed to outdoor conditions, dassoCTECH will turn grey over time creating a very natural look.

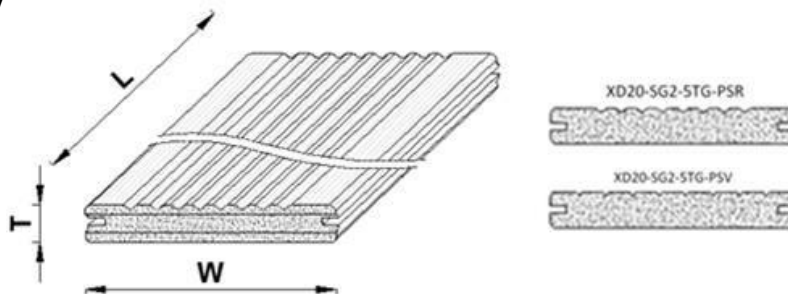

L: Lacquered, **U:** Unfinished, **B:** Bevel, **S:** Smooth, **R:** Reeded, **V:** V groove

Product code	Surface	Tenon	Finish	Edges	Dimensions (mm)
XD18-SG2-5TG-PSR	S/R	T&G	O/L/P	B	L1850*W137*T18
XD20-SG2-5TG-PSR	S/R	T&G	O/L/P	B	L1850*W137*T20
XD18-SG2-5TG-PSV	S/V	T&G	O/L/P	B	L1850*W137*T18
XD20-SG2-5TG-PSV	S/V	T&G	O/L/P	B	L1850*W137*T20

Installation summary

- Install a suitable, fixed, stable and durable sub frame.
- Determine which side of the board will be used: the grooved or flat side.
- Fix the boards on the sub frame using fasteners (to be inserted in the grooves of the board) or alternatively with screws (through the surface)

WOOD N BEYOND

WE STAND BEHIND WHAT YOU STAND ON

- After installation: make sure proper cleaning and maintenance is done, according to the chosen finish.
- When not applying outdoor oil 1x per year, the deck will fade, and the typical bamboo wood grain structure will become less visible.
- DassoCTECH is available pre-oiled or unfinished. Final treatment after installation with water-based oil/saturator is necessary for all versions.

Technical characteristics

Technical characteristics

- Moisture Content 8~12%
- Brinell hardness: 79.2N/mm² (DIN EN 1534)
- Slip Resistance(flat): 19、 B (DIN 51097)
- Slip Resistance(reed): 22、 B (DIN 51097)
- Reaction to Fire: Bf1-s1 (DIN EN 13501-1:2010)
- Modulus of Elasticity: 16700N/mm² (DIN EN 408)
- Static Bending Strength: 73.8N/mm² (DIN EN 408)
- Biological Durability: class 1 (EN 350:2016)
- Release of Formaldehyde: E1(0.19mg/m²) (GB/T17657-2013)
- Length of Swelling Rate. : 0 (DIN EN 15534-1)
- Width of Swelling Rate:0.6% (DIN EN 15534-1)
- Termite Resistance Level: DC (D) (EN117)

2.Package

WOOD N' BEYOND

WE STAND BEHIND WHAT YOU STAND ON

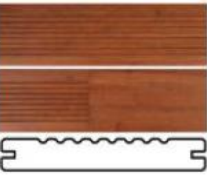
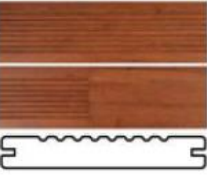
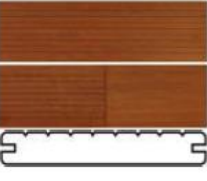
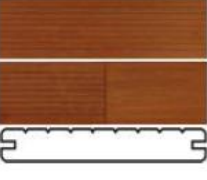
No.	Products Code	Item & Description	Photo	Size (mm)	ctns/ pallets	M2 /pallet	N.W /Pallet (KGS)	G.W/ Pallet (KGS)	pallets /20'
1	ED18-MG2-5TG-PSR	dassoCTECH, Outdoor decking-cremic treatment, Smooth+Wave face, T+G head, length sides grooved (symmetrical), Pre-primed with penetrating Oil		1850*137*18	8*27pcs/pallet	54.75	1281.15	1306.15	18pallets
2	ED20-MG2-5TG-PSR	dassoCTECH, Outdoor decking-cremic treatment, Smooth+Wave face, T+G head, length sides grooved (symmetrical), Pre-primed with penetrating Oil		1850*137*20	8*24pcs/pallet	48.66	1138.7	1163.7	18pallets
3	ED18-MG2-5TG-PSV	dassoCTECH, Outdoor decking-cremic treatment, Smooth+V-groove, T+G head, length sides grooved (symmetrical), Pre-primed with penetrating Oil		1850*137*18	8*27pcs/pallet	54.75	1281.15	1306.15	18pallets
4	ED20-MG2-5TG-PSV	dassoCTECH, Outdoor decking-cremic treatment, Smooth+V-groove, T+G head, length sides grooved (symmetrical), Pre-primed with penetrating Oil		1850*137*20	8*24pcs/pallet	48.66	1138.7	1163.7	18pallets

3. Installation Instruction

- Water logging under the decking must be avoided by preparing a water permeable ground structure. This can be achieved by sand layers and gravel dispersion above.
- Use cement/stone tiles 40-50 mm thick or pedestals to support the sub frame. See drawing.
- Place a root barrier under the tiles to prevent weeds to grow from under the decking.
- Install the decking boards with a slope of 1-2% to enable water to run off the surface.
- Ensure good ventilation of the decking by keeping at least 20 mm space at walls and obstacles and avoid closing the terrace on the sides.
- When the surface underneath the decking is not fast drying, there should be at least 100 mm distance between the decking and the surface underneath the floor.
- Use sub frame joists with the minimum size of 40x60 mm. Suitable joists are those with the same durability class as the decking; if using steel frame, the min. thickness is 3mm
- Avoid direct contact with the earth.
- Install the boards on sub frame joists with 462.5 mm space between the joists (centre- to-centre).
- Always install cut off outdoor boards on at least 3 sub frame joists.

WOOD N' BEYOND

WE STAND BEHIND WHAT YOU STAND ON

- Other sub frame joists should be installed with 5-8 mm distance between the end of the joists.

The DassoCTECH board is a natural forest product, which varies in colour, grain and appearance. Colour can change fast from dark brown to brown or grey, depending on the maintenance schedule.

Cracks and splinters on the surface and on the end of the boards will arise from the different drying characteristics of the surface and cross cut ends. Besides this the surface gets rough. This phenomenon is normal for most wood species and is minimized for this product by its patented 'Thermo-Density®' production method. Head sides cracks can be further minimized by applying wax on cross end sides of the cut boards, see below.

Dimensional change or cupping of the boards can occur after installation. This phenomenon is normal for most wood species and is minimized for this product by its patented heat-treated process.

Splinters and roughness can be removed by cleaning the surface of the decking with the silicium carbid broom or machine disk MOSO® supplies, the surface will become smooth and splinters are removed.

When using the flat side of the boards as surface please note that deformation under influence of climate will be significantly more visible. Deformation of the surface is not considered to be fault of the material.

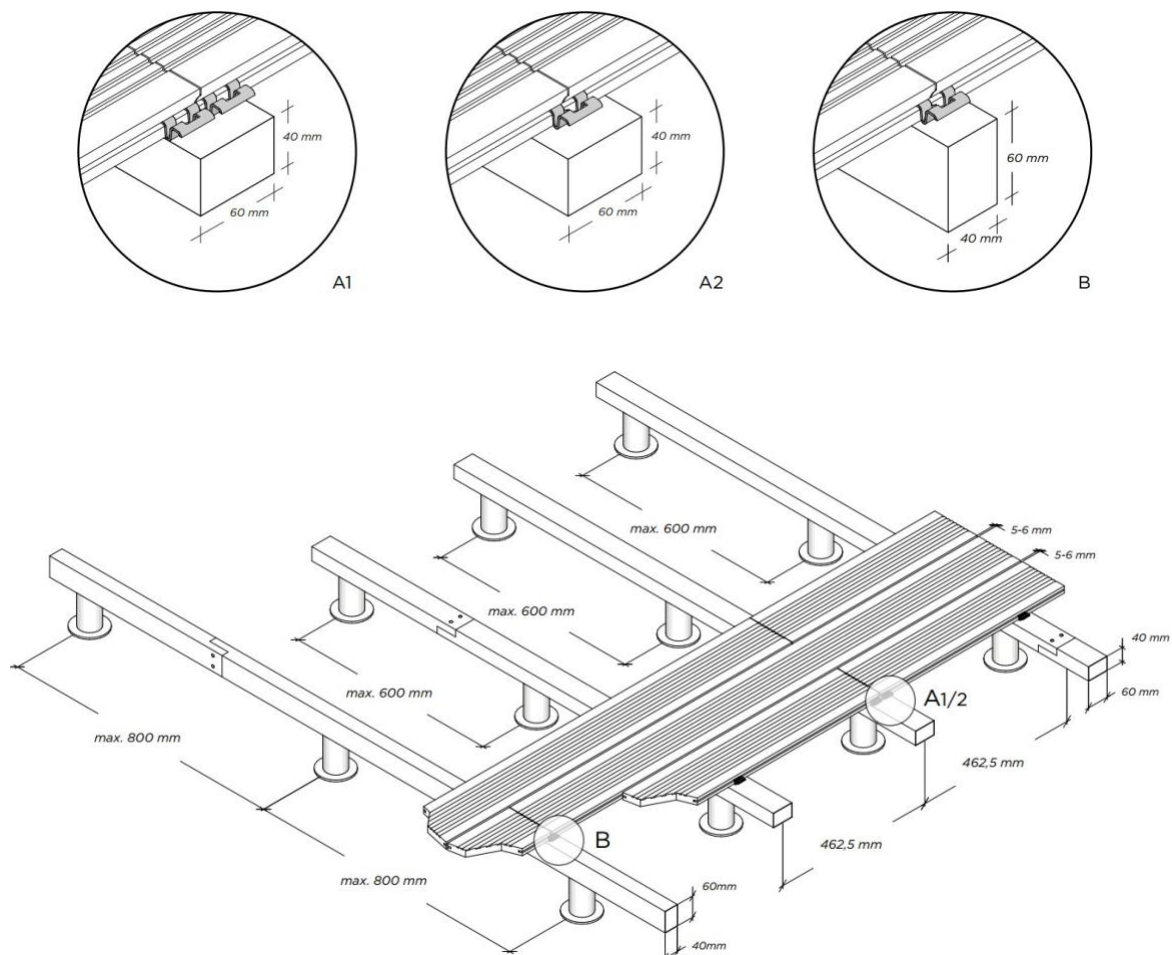

WOOD N^o BEYOND

WE STAND BEHIND WHAT YOU STAND ON

- Determine the surface side of the boards (reeded- or flat surface).
- Use fasteners or other suitable fasteners in the following sequence
- Press fastener in the groove of one board
- Pre-drill the screw holes. On hardwood/ bamboo: use 3.2-3.5 mm extended drill (11 cm long) in order to pre drill deep enough. Mount the screw without fully tightening.
- Install the following board
- Tighten the screw in the fastener and the sub beam.
- Use approx. 20/17/14 fasteners per m², this is depending on the type or board 137/155/ 178mm wide. When the tongue and groove are connected on the sub beam use 2 fasteners, 1 for every board.
- Only use the included stainless-steel decking screws (4.5 x 30 mm)
- Determine the surface side of the boards (reeded or flat surface)
- Pre-drill the screw holes 20 mm from the side of the board. Be sure to pre drill with a large enough drill to avoid cracking of the decking
- Always screw both sides (left and right) of the board
- Use stainless steel decking screws (ca 5 x 50 mm)

DassoCTECH is pre-finished with Woca waterbased saturator oil (Teak colour) on all sides.

Clean the deck surface at least once a year with WOCA soap solution or a product for cleaning exterior wood and using a silicium carbide brush or machine disk. Follow the WOCA indicator.

Apply 1-2 coats new WOCA saturator oil. This maintenance should be undertaken 1-2 times a year to prevent the bamboo turning a grayish tone and losing its characteristic bamboo grain. The first application can be performed either after installation or 3-4 months later where the pores will be more open to absorb this product. Follow instruction of Woca.

It is advisable to keep the deck clear of dust and dirt as much as possible (sweep regularly)

Store daassoXTR in a dry, cool place protected against dust and direct sunlight.

additional note

Whilst all due care is taken to ensure the accuracy of the installation instructions, individual circumstances (location, sub floor and installation procedures) may vary and are beyond the manufacturer 's control. In case of doubt, therefore, consult the distributor

Face Screwing :

TM

The Smart-Bit Pro Plug

System for Wood Installation Instructions

WOOD N^o BEYOND

WE STAND BEHIND WHAT YOU STAND ON

- What You Will Need

If you are counter sinking the screw heads dasso.XTR offers The Pro Plug System. The Pro Plug System is a complete system for plugging and it includes the Pro Plug Tool, specially engineered XTR Bamboo plugs, the Pro Plug glue nozzle, and stainless steel screws. PRO PLUG™ Glue Nozzle, DESAN, A power drill Pro Plug

Your decking or flooring manufacturer's instructions

A source of compressed air (from a small can or a compressor)

A plastic or wood mallet

A rag

How To Use The PRO PLUG™ System PRO PLUG™

Note: Before gluing, practice using the PRO PLUG™ Glue Nozzle on a few holes drilled in scrap wood. This will get the nozzle fully loaded with glue and give you a feel for how the nozzle works.:

Read your decking or flooring manufacturer's installation instructions.

Determine the locations where screws are needed.

Pre-drill holes with the PRO PLUG™ Tool for Wood. The hole is complete when the stop collar stops spinning

Blow out sawdust from the holes with compressed air.

With the work surface in a horizontal position, place the nozzle in the hole and push the glue bottle down. This will open the nozzle. Gently squeeze. Turn the bottle a 1/4 turn to ensure full coverage of the side wall. Pull the nozzle out of the hole. This will close the holes in the nozzle. The objective is to coat the inside walls of the hole while leaving as little glue at the bottom of the hole as possible.

You can glue several holes at a time and then go back to insert the plugs, so long as you do so before the glue begins to set. Use a rag to wipe off any excess glue that builds up on the nozzle tip.

Insert a PRO PLUG™ Plug in each hole, chamfered end first, with the wood grain aligned with the work piece. (Note: All plugs are face grained.) Using only moderate force, pound plugs in with a plastic or wooden mallet until flush or nearly flush with the work surface. Wipe any excess glue clean with a damp rag.

Sand the work surface. We recommend delaying sanding until after the glue has set, following the glue manufacturer's directions.

WOOD N^o BEYOND

WE STAND BEHIND WHAT YOU STAND ON

Note: PRO PLUG™ Glue Nozzles can be easily maintained and reused even after becoming caked with dry adhesive. Simply wash the nozzle clean with warm water and, if necessary, use the end of a paperclip to clear the nozzle holes.

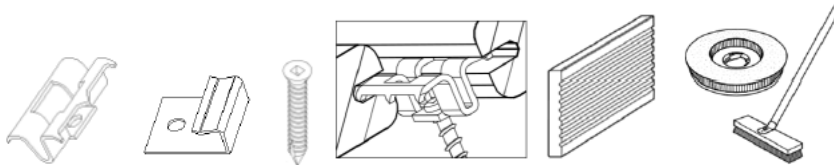

4. Maintenance Instructions

DassoCTECH decking maintenance with WOCA oil



1 2 3 4

- 1- Brand new
- 2- Half a year
- 3- A year and a half
- 4- After maintenance

Maintenance WOCA

The surface of decking is weathered under influence of wind, rain, frost and sunshine (UV). As a result, the surface fades, dirt and cracks/splinters will appear.

WoodCare Denmark has developed different outdoor cleaning-and maintenance products. WOCA Exterior Cleaner loosens dirt and removes green growth from the surface, without damaging it.

Cleaning

Rinse the surface, make sure the decking completely wet.

Mix exterior cleaner with water in the ratio 1:2 and apply it. If the decking extremely dirty, exterior cleaner may be used undiluted.

Clean the decking with a silicium carbid brush or machine disk.

Scrub the decking following the bamboo grain until the surface appears clean.

Leave the decking to dry for approx. 24 hours. The decking must be completely dry before coating the oil.

WOOD N^o BEYOND

WE STAND BEHIND WHAT YOU STAND ON

Coating

Apply in dry weather only. Avoid direct sunshine and high temperatures.

Stir the oil thoroughly before use. Coating with a brush.

After few minutes, the decking has an oily appearance as the water is evaporating.

Wipe any excess oil with clean cotton cloths after no more than 5~10 minutes. including joints and grooves.

The decking needs 24 to 48 hours for completely dry.

Risk of self-ignition

Due to the risk of self-ignition it is important that oil-wetted cloths are soaked in water and are disposed in a tightly closed container after use.

5.Warranty

1. Scope of the Warranty

1.1 This Warranty is exclusive to the original purchaser of dassoCTECH® Products from the Zhejiang Xinhaiye Bamboo Technology Co., Ltd. (hereinafter referred to as "Manufacturer")

1.2 Products covered by the Warranty - the dassoCTECH® Products

The Warranty covers all dassoCTECH® decking and cladding (hereinafter referred to as dassoCTECH® Products). Manufacturer warrants that all dassoCTECH® products are produced to the specifications described in the Product Data Sheets issued by dassoCTECH valid at the time of purchase. These Data Sheets can be downloaded from dassoCTECH.com.

1.3 Damage covered by the Warranty

1.3.1 Subject to the conditions set out herein, dassoCTECH® tech warrants that from the date of delivery as stated on the invoice and for a Warranty Period following delivery as defined below, the dassoCTECH® Products applied in Use Class 4 as defined by EN 350 and EN113 will not be damaged by decay caused by wood decay basidiomycete fungi and the wood destroying fungi Coniophora puteana, Trametes (Coriolus), Pleurotus ostreatus so that the dassoCTECH® Products do not perform according to their intended function.

1.3.2 Manufacturer guarantee the construction and the gluing of the dassoCTECH Product

1.4 Warranty Period

dassoCTECH® products: 25 years

2. Remedy

2.1 Manufacturer shall, at its own option, either re-deliver or compensate by cash payment any dassoCTECH product affected by damage described as cause for remedy above. Any cash compensation shall be limited to the value of the original invoice for the purchase.

3. Conditions

This Warranty shall be subject to the following terms and conditions :

3.1 Environmental conditions such as air pollution, mold, mildew, etc., or staining from foreign substances such as dirt, grease, oil, etc. Please note: Should dusts and pollens build up on your deck, these become a food source for molds and mildew to grow in and their waste products will stain the dassoCTECH®. Please keep your deck clean as we do not warrant against these types of staining and degrade. Mold and mildew will not grow in/on dassoCTECH® itself but will in/on the dusts/pollens.

WOOD N^o BEYOND

WE STAND BEHIND WHAT YOU STAND ON

3.2 Claims must be made in writing to Manufacturer within 30 days after discovery of suspected damage, accompanied by this original Certificate of Warranty, copies of the relevant receipt(s), a statement describing the damage and photographs showing the suspected damage. Discovery is defined as the point in time when the suspected damage was discovered, or should have been discovered, by the Owner / Original Purchaser.

3.3 Manufacturer reserves the right to inspect the dassoCTECH products prior to any authorisation by Manufacturer of any replacement, financial repair or other remedy under this Warranty. From the date a potential claim is detected, the claimant must take all reasonable steps to protect the dassoCTECH[®] product from further damage and all reasonable steps to mitigate potential losses caused by the suspected damage.

3.4 All warranties are valid on the condition that dassoCTECH Installation Guidelines, User Maintenance Guidelines, and other dassoCTECH product documents valid at the time of purchase are observed and followed at the handling, storage, installation and use of the Products. Failure to install dassoCTECH[®] Product in accordance with dassoCTECH instructions will invalidate this Warranty.

3.5 This Warranty does not cover any costs associated with removal of damaged dassoCTECH[®] products or installation of replacement dassoCTECH[®] products or any remanufacturing costs.

3.6 A claim does not lead to an extension of the warranty period.

3.7 Failure to follow these procedures may invalidate any claim under this Warranty.

4. Exclusions

4.1 Manufacturer is not liable for any incidental, economic, exemplary, special, punitive or consequential damage, whether direct or indirect, howsoever arising.

4.2 The statements in this Warranty constitute the only warranties given by Manufacturer, and all other express or implied warranties, including any implied warranties of merchantability or fitness or a particular purpose (save where arising under applicable product warranty laws that cannot be lawfully disclaimed) are expressly excluded.

4.3 Damage or defects resulting from or in any way attributable to the causes listed below is not covered by the Warranty:

a) Improper storage, handling, installation or use of the dassoCTECH[®] Product, including but not limited to any damage where good design and installation practices have not been followed;

b) Misuse, neglect, alteration or abuse of the dassoCTECH[®] Product;

c) settlement or structural movement and/or movement of materials to which the dassoCTECH[®] Product is attached;

d) Damage from incorrect design of any structure or where the maximum designed wind loads are exceeded for any structure;

e) Acts of nature, such as inter alia hurricane, tornado, hail, earthquake, flood or other severe weather or natural phenomena;

e) Any cause other than manufacturing defects attributable to dassoCTECH.

f) DassoCTECH board is a natural forest product, which can vary in colour, grain and appearance.

Colour can change over time depending on the maintenance schedule. Colour change cannot be a reason to make a claim.

g) Small cracks on the surface and on the end of the boards can arise from the different drying characteristics of the surface and cross cut ends. This phenomenon is normal for most wood species and cannot be a reason to make a claim.

) The surface sides of the boards can get rougher and even splinter over time as a result of constant shrink and swell of the boards due to dry and wet climate periods. This phenomenon is normal for most wood species and cannot be a reason to make a claim.

WOOD N BEYOND

WE STAND BEHIND WHAT YOU STAND ON

- i) Slight dimensional change or cupping of the boards can occur after installation. This phenomenon is normal for most wood species and cannot be a reason to make a claim.
- j) The guarantee applies only to the original purchaser and cannot be transferred.